



Sea-B-Que Operating and Installation Instruction Manual



KEEP THIS MANUAL FOR FUTURE REFERENCE

Large & Small Sea-B-Que

** Please read from beginning to end before operating.

CBQ Serial #: _____

Quality Controlled by- Doug & Don

Form#7.2-239 Issue#2 Oct 21, 2011

www.dickinsonmarine.com ~ info@dickinsonmarine.com

Form#7.2-239 Issue#2

Table of Contents

Table of Contents...	Pg. 2
1. Warning & Disclosures...	Pg. 3
2. Sea-B-Que Packing List...	Pg. 4
3. Assembly...	Pg. 4
4. Propane Fuel Connection...	Pg. 5
5. Low Pressure System Connection...	Pg. 5
6. Leak Test...	Pg. 6
7. Getting to Know your Sea-B-Que...	Pg. 7
8. Lighting & Operation...	Pg. 8
9. Temperature Adjustment...	Pg. 9
10. Cleaning & Maintenance...	Pg. 10
11. Cooking...	Pg. 10
12. Sea-B-Que Accessories & Parts Available...	Pg. 10
13. Warranty...	Pg. 11
14. Registering your Warranty...	Pg. 14

Warnings & Disclosures

- The Sea-B-Que barbeque is designed to use only LPG fuel.
- Read this owner's manual carefully and completely before trying to assemble, operate, or service this barbeque.
- Improper use of this gas appliance can cause serious injury or death from burns, fire, explosion, carbon monoxide poisoning and oxygen depletion.
- Do not install this appliance in spaces containing internal combustion engines, fuel tanks, or joints and fittings.
- Test all propane lines and connections for leaks with a soapy water solution. Do not use a flame to test for leaks.
- If the information in this manual is not followed exactly, a fire or explosion may result causing property damage, personal injury, or loss of life.
- Do not store or use gasoline or other flammable vapors and liquids in the vicinity of this or any other appliance.
- Close the LPG cylinder valve when Sea-B-Que is not in use.
- Close the Sea-B-Que regulator valve before opening the LPG cylinder valve.
- Close the LPG cylinder valve in the event of an emergency.
- Close the LPG cylinder valve when the boat is unattended.
- Always open the hood before lighting.
- Do not allow LPG cylinder to lie on its side.
- If the burner does not light immediately turn control regulator to lock-off position and do not attempt to light the burner for at least 60 seconds.
- Trim excess fat from meats to minimize flare-ups.
- Let the barbeque cool before cleaning or removing any parts for cleaning or servicing.
- This barbeque is for OUTDOOR USE ONLY. Do not operate inside a boat, garage, shed or other enclosed areas.

Sea-B-Que Packing List

***PLEASE KEEP YOUR PROOF OF PURCHASE FOR WARRANTY.**

Sea-B-Que Large: 00-SBQ-L

1. Top Lid and Main Body Assembly
2. Thermometer part# 15-120
3. Top Lid Knobs part# 15-130
4. Side handles part# 15-140
5. Porcelain Grill Section part# 15-183-P (4 required)
6. Stainless Burner & Bracket part# 15-060
7. Orifice Assembly part# 15-072
8. Regulator Control part# 15-110
9. Spark Igniter part# 15-101
10. Drip Tray part# 15-080
11. Deck Legs

Sea-B-Que Small: 00-SBQ-S

1. Top Lid and Main Body Assembly
2. Thermometer part# 15-120
3. Top Lid Knobs part# 15-103
4. Porcelain Grill Section part# 15-182-P
5. Stainless Burner & Bracket part# 15-061
6. Orifice Assembly part# 15-073
7. Regulator Control part# 15-110
8. Drip Tray part# 15-080
9. Deck Legs

Assembly

You will need to attach the feet of the BBQ to the rest of the unit. The two feet of the Sea-B-Que slide on to the inserted studs on the base. The flanges are to point outwards. Use the four 10 x 32 nuts and #10 lock-washers to secure the legs to the base. The drip tray is placed in the area between both legs. The 4 porcelain grill sections will sit on the ledges provided above the burner. Remember to remove all protective plastic from the body.

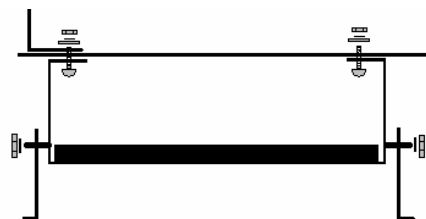

www.dic

narine.com

Form#7.2-239 Issue#2

Propane Fuel Connection

The most common LPG connection is the 1 lb. disposable bottle that connects directly to the barbeque or a hose straight from the barbeque to a 10lb. or 20 lb. tank. We have 6ft part# 15-188 and 8ft part# 15-189 high pressure propane hoses available. **High** pressure propane is required with the regulator control included with the Sea-B-Que. The Sea-B-Que gas control is also the pressure regulator part# 15-110.

If your boat has a regulated propane source, the fuel line to the Sea-B-Que must be tee'd off before any regulators on the main fuel supply. A high pressure T type connector is available from Dickinson for this. *See the high pressure T connection diagram below.

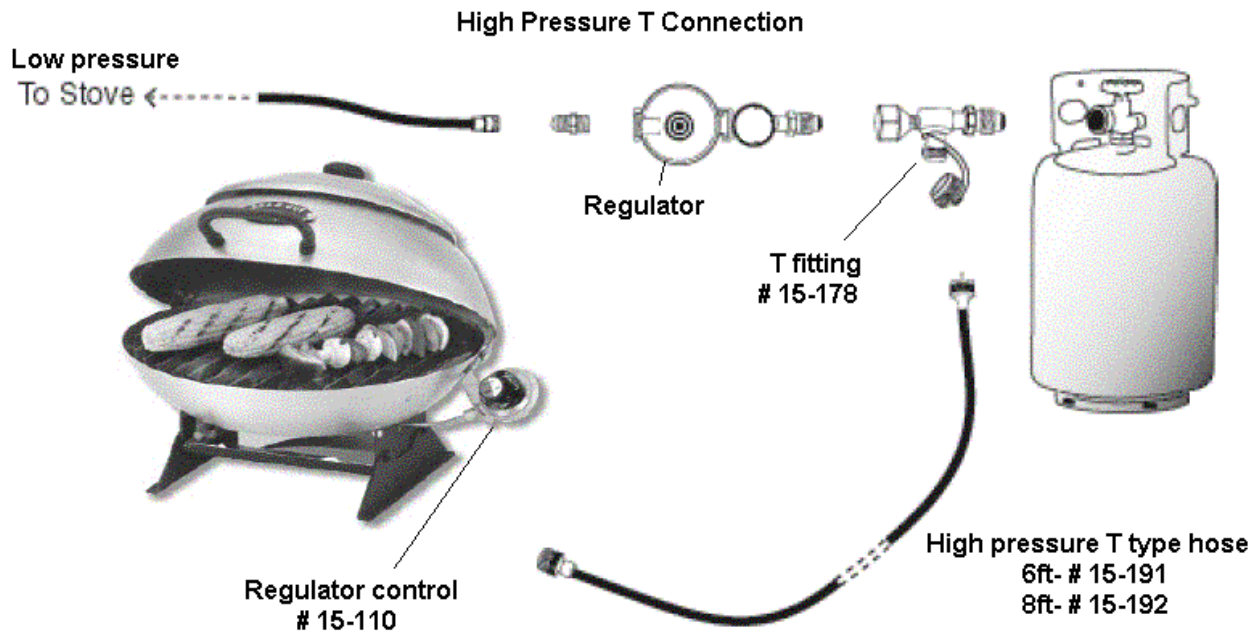

Low Pressure System Connection:

If you already have a low pressure line available for your Sea-b-que, you would then need to replace the regulator control part# 15-110 with low pressure gas valve part # 15-193. If doing so, there **MUST** be a separate 11” WC low pressure regulator part# 19-151 at the bottle regulating the propane. *See the low pressure connection diagram below.

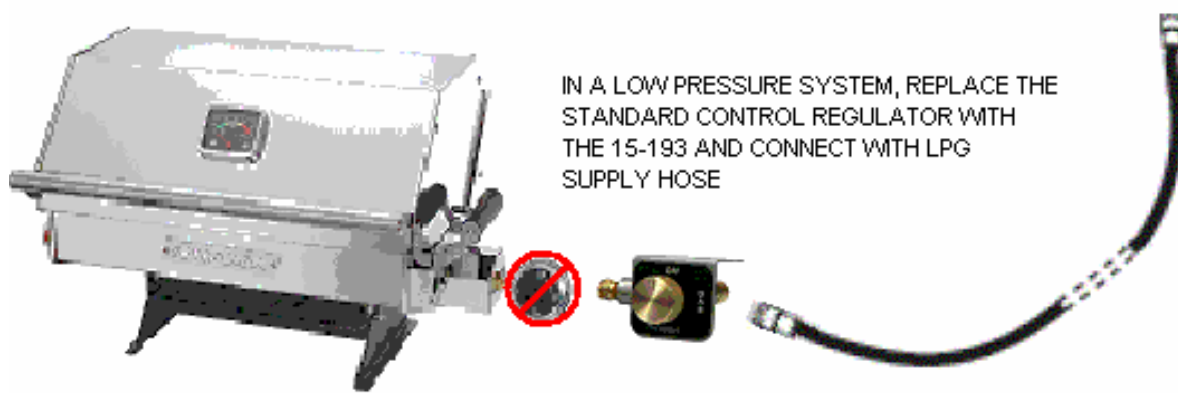

Typical Low Pressure Propane Locker

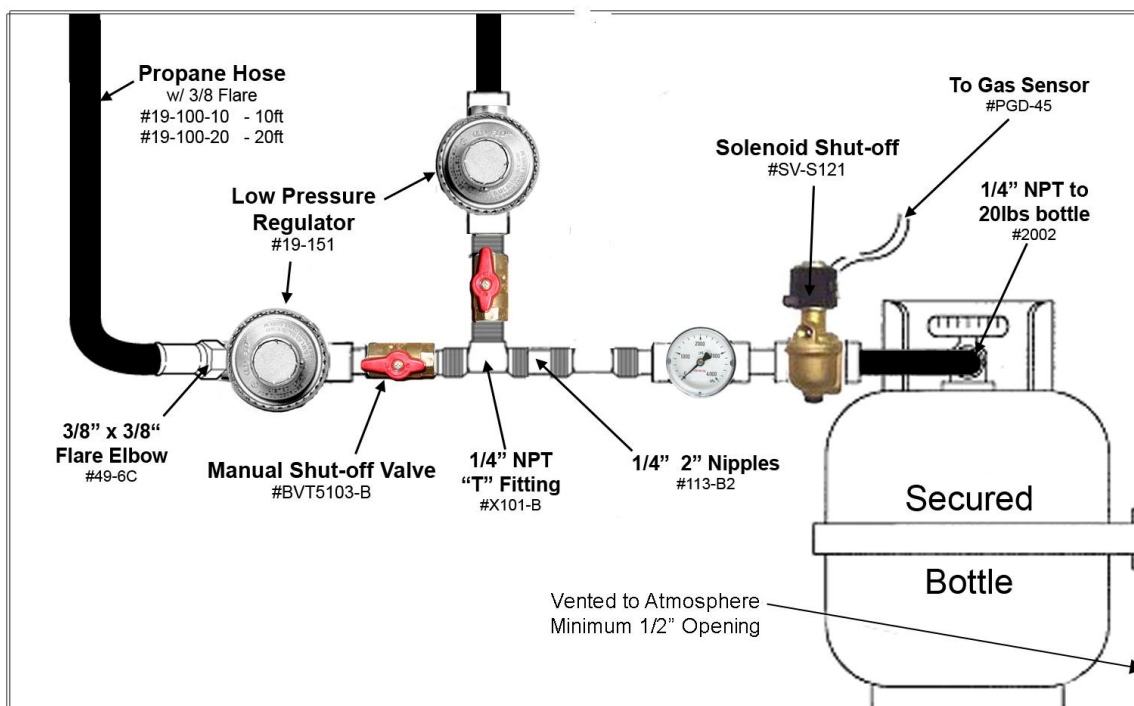

Leak Test:

1. Do not use or permit sources of ignition in the area while doing the leak test. This includes smoking.
2. Leak testing solution should be half liquid soap and half water.
3. Apply the solution to the LP gas delivery system at all connections.
4. Bubbles in the soap solution indicate that a leak is present.
5. The leak(s) must be stopped by tightening the loose joints, or replacing the faulty parts.

*****DO NOT USE BARBEQUE UNTIL LEAK IS CORRECTED*****

Getting to Know your Sea-B-Que

Thermometer:

The Large and Small Sea-B-Que are fitted with a thermometer. If you remove the thermometer for cleaning or replacement, see below for re-assembly diagram. Inspect the thermometer to ensure no small white bits of plastic are around the edge, left over from the protective plastic used in the manufacturing process. Be aware that bending or damaging the thermometer probe or dropping the Sea-B-Que, may cause the thermometer to stop working. (use #6 x 1/4 screws)

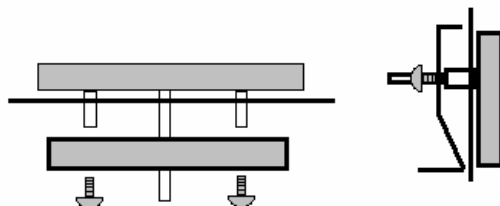

Spark Igniter: (Large model only)

The igniter probe should be as close to the holes in the burner as possible. See diagram below. For a perfect fit, adjust the probe so that it is 3/16ths“(4.75mm) away from the holes. Igniters seldom fail but if yours stops working try cleaning the probe. Built up grease may have coated the probe, preventing the spark. Remove the igniter, clean the bracket and around the base, the copper line on the side of the igniter and the screws. Built up grease may have interrupted the ground. (use #8 x 3/8 screws & #8 nuts)



Orifice Assembly:

The orifice assembly is the series of brass fittings that attach to the gas regulator control and go inside the end of the burner. The orifice has a tiny hole that controls the maximum amount of fuel allowed to enter the burner. From time to time salt or other debris may plug the hole changing the flame. The Sea-B-Que will not get hot, and a blocked orifice may be the reason. Remove and clean with a very small wire (twist tie). Do not expand the hole or the Sea-B-Que will burn too hot.

The Burner:

Your burner bar is made of stainless steel and is the most rugged, longest lasting marine burner bar around. Salt air, heat and acids in foods however still take their toll on the burner bar. Try to keep the burner clean and free of obstructions. The venturi may need adjusting to your liking. When the slots line up, the flame will be vibrant blue (more like a broiler flame), when the slots are closed, the flame will be lazy yellow (more like a burning briquette bbq), or they can just be left in the middle. (use #8 x 3/8 screw & nut)

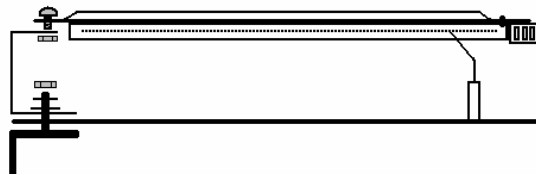

Lighting

- 1) Sea-B-Que control regulator in LOCK-OFF position
- 2) Open Lid and turn on LPG gas supply at source
- 3) Turn Control Regulator ON to the medium level. Press Igniter button several times, or use a long bbq lighter through the match hole. Check to make sure the propane is burning.

****If the burner does not light immediately turn control regulator to lock-off position and do not attempt to light the burner for at least 60 seconds.**

Operation

When the burner is lit the Control Regulator setting may be selected. With the lid closed the Sea-B-Que will quickly reach cooking temperatures (approx. 5 minutes).

Do not leave the control regulator on high with the lid closed for long periods of time or damage may be caused to the body of Sea-B-Que due to overheating. High gas settings are only recommended for a short pre-heat period, barbequing with the lid open, or with the lid closed, but at a moderate setting. After cooking, turn the Sea-B-Que off at the LPG source. Once the burner has extinguished, turn the Control Regulator to the LOCK-OFF position. This will de-pressurize the fuel line.

dickinson MARINE



BBQ TEMPERATURE ADJUSTMENT PROCEDURE

• Venturi Adjustment...

The venturi is what lets air mix with the propane fuel, in your barbeque. It may need to be adjusted to obtain your optimal temperature. If it is closed (fig 1), then simply open it, by loosening the phillips head screw, and move it until the vent holes are open. (fig 2)

Opening it will help introduce more air into the burner, which will in turn, bring down your flame temperature. If you want to increase your flame temperature, then just close the venturi.

Accessing the venturi screw is easily done without removing the burner from the barbeque, as it's located in the box connecting the regulator to the barbeque.

• Regulator Adjustment...

After adjusting your venturi, you may still need to adjust the regulator, to obtain the optimal running temperature.

First you need to make sure your bottle of propane is at least 1/2 full. Then light the burner and turn it to the high setting.

Now remove the sticker on the regulator (fig 3) and adjust the screw to increase or decrease the flame. Your regulator will have either an allen screw, flathead screw, or phillips screw. For this reason, some regulators will turn clockwise to decrease the flame, and some will turn counter-clockwise.

So you'll need to adjust the screw first about 1/2 a turn to see which direction you'll need to be turning it, for further adjustment.
WHEN ADJUSTING, MAKE SURE TO ONLY DO 1/2 A TURN AT A TIME

You should have the regulator on the high setting when adjusting your flame to optimal condition. But after you've adjusted it, you should also test it at the low setting, to ensure you didn't adjust it too much. Decreasing the regulator too much, can cause the flame to blow out on windy days, especially on the low setting.

After adjustments are made, you can enjoy your barbeque at its most optimal running condition

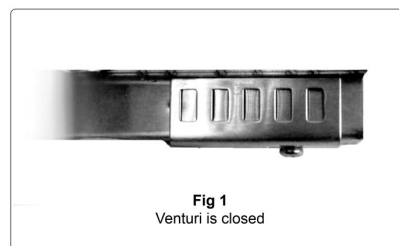

Fig 1
Venturi is closed

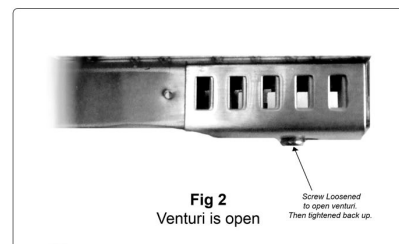

Fig 2
Venturi is open
Screw Loosened to open venturi. Then tightened back up.



Fig 3
Remove Sticker



Fig 4
Adjustment Screw

Cleaning and Maintenance

- 1) Clean grease from the drip tray and the base of the Sea-B-Que regularly.
- 2) Clean burner and burner orifice seasonally. The burner orifice can be removed for thorough cleaning with hot water and a bronze wire brush.
- 3) The Sea-B-Que stainless top lid and main body **will** eventually discolor with heat.
- 4) The marine environment can take a harsh toll on all stainless steel barbecues. The Sea-B-Que is made of high quality 304 stainless steel. However, the chlorine and sodium chloride in the ocean water mixed with the heat of the Sea-B-que creates some surface corrosion. It is therefore recommended to keep up with regular cleaning and maintenance to keep your Sea-B-Que in pristine condition. The use of oven cleaner and a non-metallic abrasive pad such as scotchbrite on the exterior surface is also recommended. Stainless steel polish, if available, will also enhance the look of your Sea-B-Que. Rubbing the surface of the stainless steel with the grain will remove the rusty appearance and will keep your Sea-B-Que looking shiny and new for many years to come. Dickinson has a scotchbrite pad cleaning kit available part# 15-555.
- 5) A defective spark igniter is uncommon. If the igniter does not work, it will be caused by grease build-up on the wire electrode or by the igniter mount not being grounded to the body of the barbecue during assembly. The igniter can be cleaned with hot water and a cloth.

Cooking

The removable drip tray must be installed prior to cooking. Do not allow grease to build-up in the grease tray or in the base of the Sea-B-Que. The porcelain enamel cooking surface plates should be pre-heated and sprayed or covered with cooking oil to prevent food from sticking. Accumulated grease will burn off if the cooking plates are turned over. Barbecues will get hot and splash grease, and for safety reasons it is therefore advisable to mount the unit outboard.

Sea-B Que Accessories & Parts Available

#15-150A	Universal Rail Mount Kit
#15-150F	Fishing Rod Holder Mount Kit
#15-187	Taff Rail Mount Kit
#15-150P	Scotty Mount Kit
#15-185	Small Black Canvas Cover
#15-184	Large Black Canvas Cover
#15-180	Small Food & Drink Tray c/w Cutting Board
#15-181	Large Food & Drink Tray c/w Cutting Board
#15-200	Small Aussie griddle (8" x 9")
#15-201	Large Aussie griddle (9.5" x 11")
#15-188	6 ft. Propane Hose – High Pressure
#15-189	8 ft. Propane Hose – High Pressure
#15-191	6ft. Propane T Type Hose – High Pressure
#15-192	8ft. Propane T Type Hose – High Pressure
#15-178	“T” type Connector
#15-193	Low pressure Control Valve
#19-151	Low pressure Regulator
#19-100-10	10 ft. Low Pressure Hose
#19-100-20	20 ft. Low Pressure Hose
#15-555	BBQ Cleaning Kit
#15-182-P	Small Porcelain Grills *4 needed
#15-183-P	Large Porcelain Grills *4 needed
#15-182-S	Small Stainless Steel Grills *4 needed
#15-183-S	Large Stainless Steel Grills *4 needed
#15-080	Large & Small Drip Tray
#15-060	Large Burner & Bracket
#15-061	Small Burner & Bracket
#15-072	Large Orifice Assembly
#15-073	Small Orifice Assembly
#15-101	Large Model Spark Igniter
#15-110	Regulator Control
#15-120	Thermometer
#15-194	Adapter for European Gas Canisters

**To place an order visit www.dickinsonmarine.com

Warranty Policy

We at Dickinson wish to maintain a reasonable and easy system for warranties, returns and exchanges. To accomplish this, we would like to inform you of some helpful guidelines and procedures to use and follow when sending back product to Dickinson Marine. All correspondence regarding returns, warranties and exchanges will go through the factory of Dickinson Marine in Coquitlam, BC, Canada and the product MUST be returned to this location.

Warranty

Dickinson Marine warranties all of its products for a period of one year dated from the purchase of the product by the end user with proof of purchase or a registered warranty. We warrant our barbeque burners for a period of 3 years dated from the purchase of the product by the end user with a registered warranty. The warranty card should be copied for your records and returned to Dickinson to activate your warranty within 90 days of your purchase. You can also activate it online at www.dickinsonmarine.com
A copy of the warranty card must have been received or a proof of purchase must be presented to receive the warranty.

1. The customer can contact us directly to settle any warranty issues. We are pleased to help. Call us toll free 1-800-659-9768 or email: info@dickinsonmarine.com
2. If the customer is returning a complete product they see as defective, be sure the product has been assembled correctly and is being used correctly. If you are not sure please call our Technical Help Department @ 1-800-659-9768. Dickinson Marine will not provide credit for used products that are not defective. In these cases, it is best to call the factory to determine if the product is being used correctly or has been assembled correctly or is in fact defective.
3. All products being sent back to Dickinson Marine must have a Return Authorization Number. Contact us at Dickinson Marine toll free 1-800-659-9768 or e-mail info@dickinsonmarine.com to obtain a Return Authorization Number. This allows us to track and process your return. Once you have received an RA# from us, include your proof of purchase and ship to the address below. We recommend you

ship using the mail service insured and retain a tracking number. Customers are responsible for the shipping costs for all returns and exchanges.

Dickinson Marine Returns
Unit# 101-17728 66 Avenue
Surrey, BC
V3S 7X1 Canada

4. Products that are demonstrably older than the warranty period or those that have obviously been misused will not be returned, exchanged, or repaired.

Non-defective Returns & Exchanges

Dickinson reserves the right to apply a 20% restocking fee for returned product sent back. An RA # will be needed from the factory to facilitate any return. Credits will be made at the last purchased price for that part number.

Limited Warranty

WARRANTY PROVISIONS: Dickinson warrants this product to be free of defects in workmanship and materials for a period of one year. This warranty is limited to claims submitted in writing within a one-year period following the date of purchase. If any part of your new product fails because of a manufacturing defect within the warranty period Dickinson offers to replace said parts free of charge, provided, however, that such parts have not been improperly repaired, altered or tampered with or subjected to misuse, abuse or exposed to corrosive conditions. This warranty, however, is limited by certain exclusions, time limits and exceptions as listed below. Read these limitations and exclusions carefully.

TIME LIMIT: This warranty is given too and covers only the original purchaser. Coverage terminates one year from the date of purchase for parts replacement.

EXCLUSIONS : This warranty does not cover or include : (a) Any normal deterioration of the product and appearance of items, due to wear and/or exposure; (b) any guarantees, promises, representations, warranties or service agreements given or made by an authorized distributor or other person selling this product, other than those specifically stated herein; (c) any damage or defect due to accident, improper repair, alteration, unreasonable use including failure to provide reasonable and necessary maintenance, misuse or abuse of the equipment, or exposure to corrosive conditions. This warranty is conditioned upon normal use, reasonable and necessary maintenance and service of your product, and written notice being given promptly upon Buyer's discovery of a warranty claim, pursuant to paragraph 6 below. Reasonable and necessary maintenance is

maintenance which you are expected to do yourself or have done for you. It is maintenance, which is necessary to keep your product performing its intended function and operating at a reasonable level of performance.

DAMAGE LIMITATION WARNING : IN NO EVENT SHALL Dickinson BE LIABLE FOR ANY INCIDENTAL OR CONSEQUENTIAL DAMAGES, INCLUDING (BUT NOT LIMITED TO) LOSS OF USE OF THE PRODUCT, LOSS OF TIME, INCONVENIENCE, EXPENSES FOR TRAVEL, LODGING TRANSPORTATION CHARGES, LOSS BY DAMAGE TO PERSONAL PROPERTY OR LOSS OF INCOME, PROFITS OR REVENUE.

ORAL OR IMPLIED WARRANTY LIMITATIONS: The foregoing warranty is exclusive and in lieu of all other warranties, written or oral, expressed or implied, including but not limited to any warranty or merchantability or fitness for a particular purpose.

TRANSFER LIMITATIONS: This warranty is not assignable or transferable. It covers only the original purchaser.

CLAIM PROCEDURE: In the event of a defect, problem or that a breach of this warranty is discovered, in order to protect any warranty rights you must promptly notify Dickinson. Give name, address, and model name, location of unit, description of problem and where you can be reached during business hours.

RESERVED RIGHT TO CHANGE: Dickinson reserves the right to make changes or improvements to products it produces in the future without imposing on itself any obligations to install the same improvements in the products it has previously manufactured.

SECOND OR SUBSEQUENT OWNER: Dickinson does not give any warranty to secondary or subsequent purchasers, and it disclaims all implied warranties to such owners.

INSPECTION: To assist you in avoiding problems with your product and to validate this warranty you are required to do the following: (a) read the warranty; (b) inspect the product. Do not accept delivery until you have examined the product with your supplier; (c) ask questions about anything you do not understand concerning the product.

OWNER REGISTRATION: Fill out the WARRANTY CARD within 30 days from the date of delivery. **WARRANTY: RETURN OF THE CARD IS CONDITION PRECEDENT TO WARRANTY COVERAGE AND PERFORMANCE. IF YOU DO NOT FILL OUT AND MAIL THE CARD AS DIRECTED, YOU WILL NOT HAVE A WARRANTY.**

Register your Warranty.....

Please register your warranty with Dickinson Marine. Fill out and send back the warranty registration below. Make sure to include the serial # for our records.

No warranty will be extended for improper installations. Use of any unapproved materials, equipment, or installation procedures will result in a voided warranty. Do not use any substitutes of the heaters valve, burner or fan other than the ones supplied by Dickinson. Dickinson Marine accepts no liability for any damage or loss of service resulting from unapproved modifications.

Warranty Form

I have read and understand the Limited Warranty and the entire Instruction Manual and agree to the terms and conditions. (PLEASE PRINT)

Name: _____

Address: _____

Phone: _____

Sea-B-Que Model: _____

Sea-B-Que Serial #: _____

Date of Purchase: _____

Seller's Name: _____

Seller's Location: _____

Signature: _____

This warranty form can also be filled out online. www.dickinsonmarine.com

Dickinson Marine

#101-17728 66 Avenue, Surrey, BC

V3S 7X1 Canada

Tel: 604-574-8641

Fax: 604-574-8659

E-mail: info@dickinsonmarine.com

Website: www.dickinsonmarine.com

All rights reserved. No part of this manual may be reproduced without permission in writing from Dickinson Marine. Dickinson also reserves the right to modify or change without notice, any materials, applications, equipment, accessories, and/or prices. All measurements and weights are approximate.