

# Radex 1 & Radex 2

---

## Operator's Manual

This manual must be read  
and the requirements carried out  
to ensure satisfactory performance.

DICKINSON RESERVES THE RIGHT TO MAKE CHANGES TO PRODUCTS OR DOCUMENTS AT  
ANY TIME

QUALITY INSPECTED BY- Doug & Don AUG. 26<sup>TH</sup> 2011

[www.dickinsonmarine.com](http://www.dickinsonmarine.com) ~ [info@dickinsonmarine.com](mailto:info@dickinsonmarine.com)

Form# 7.2-63 (1)

## Warnings and Disclosures

- FOLLOW ALL INSTALLATION AND OPERATING PROCEDURES
- WARNING! DO NOT MOUNT THIS HEATER IN THE BILGE AREA OR IN AN AREA THAT DRAWS AIR FROM THE BILGE.
- WARNING! ENGINE COOLANT OR BOILER HEATED WATER CAN CAUSE INJURY AND PAINFUL BURNS. USE CAUTION AND ENSURE ALL CLAMPS AND FITTINGS ARE TIGHT AND SECURE
- WARNING! ENSURE HANDS, WIRES, LOOSE CLOTHES AND OTHER OBSTRUCTIONS ARE CLEAR OF THE FAN (S) IN THE HEATER BEFORE OPERATION.
- DO NOT USE SUBSTITUTE PARTS

**Keep your proof of purchase and product serial number for warranty**

## Diagram

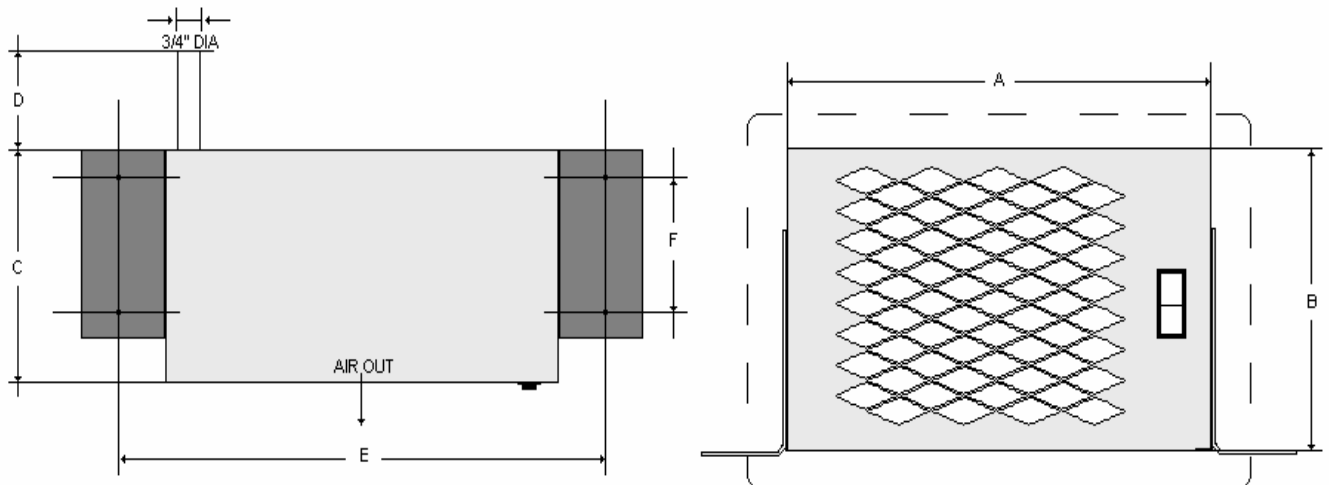

|         | A                   | B                  | C                 | D                 | E                   | F                 |
|---------|---------------------|--------------------|-------------------|-------------------|---------------------|-------------------|
| Radex 1 | 10.38" /<br>26.37cm | 7.00" /<br>17.78cm | 5.00" /<br>12.7cm | 2.00" /<br>5.08cm | 12.38" /<br>31.45cm | 3.00" /<br>7.62cm |
| Radex 2 | 16.88" /<br>42.88cm | 7.00" /<br>17.78cm | 5.00" /<br>12.7cm | 2.00" /<br>5.08cm | 18.00" /<br>45.72cm | 3.00" /<br>7.62cm |

|         | VOLTS | AMPS | CFM | BTU/HR -<br>KW  | WEIGHT       |
|---------|-------|------|-----|-----------------|--------------|
| Radex 1 | 12    | 0.74 | 100 | 12000/<br>3.5kW | 6.5lbs / 3kg |
| Radex 2 | 12    | 1.48 | 200 | 24000/ 7 kW     | 9lbs / 4kg   |

**Note:** 24 volt motors may be in stock depending on inventory stock

## Your Radex Heater

Thank you for choosing the Radex water to air heat exchanger. The Radex heater is designed to efficiently use the waste water heat produced by a water cooled engine or a hot water boiler system, to generate a source of forced air heat. The Radex is suitable for use in boats, RVs, trucks, cars and anywhere else a source of circulating hot water and 12v power is available.

There are two Radex models, the Radex 1 and the larger Radex 2. Each use a very quiet, low amp draw fan to push air through the heated coil to heat a space.

## Mounting Kits

Two mounting kits are available for the Radex 1 and Radex 2.

Side mount bracket kit 22-001 fits both the large and the small Radex and is used to mount the Radex to the floor, a wall or ceiling. The frame mount kit (22-002 for Radex 1 and 22-003 for Radex 2) is used to install a recessed Radex flush in a bulkhead or cabinet with a trim panel.

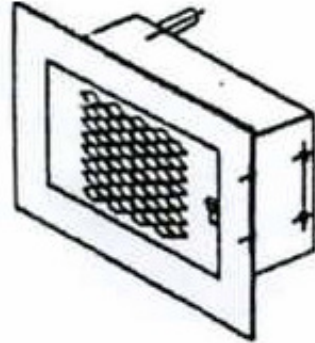

The "Frame Mount Kit" allows for recessed installation into a bulkhead or cabinet.

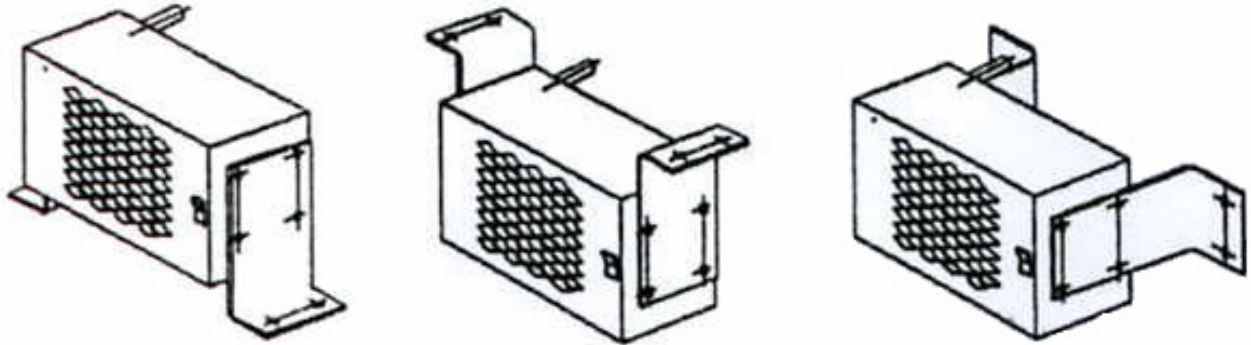

Using the "Side Mount Bracket Kit" for the Radex, you can mount the unit to a wall, floor or ceiling in a number of different ways.

## Blower Fan

Your Radex is equipped with one or two low amp 12v fans. Each fan is controlled by a separate on and off switch. We suggest that a 3 amp fuse be used in the installation.

## Installation

To make sure your unit has an adequate air supply install the Radex so there is at least 2" (5.08cm) of airspace behind the fan.

Connect the circulating hot water to the pipes as shown. The outside dimension of the copper tubing is a 3/4" diameter (1.9cm). If using 5/8ths heater hose, ensure the clamp is secure at the end of the hose to prevent slipping. We recommend the use of compression fittings with a 3/4" diameter female tube to a 5/8" diameter male hose barb fitting (and hose clamp).

Operate the heater and check all connections for leaks prior to final installation into wall or cabinet.

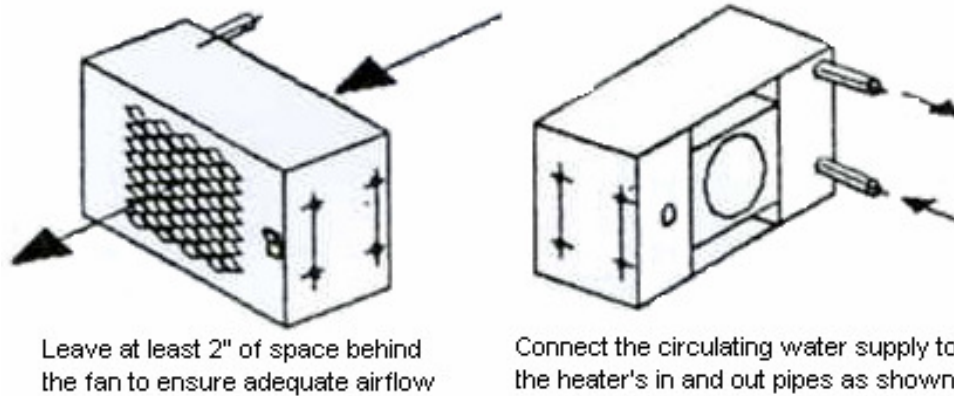

After the fan wiring and water installation are complete, secure the Radex in the mounted position with the desired mounting kit.

Fresh water cooled engines should mount the heater below the level of the radiator cap or use an air bleeder to prevent trapped air locks. The Radex 2 has an installed manual air bleed valve. Be sure the hoses are not kinked or restricted in any way.

REPORT ANY DEFICIENCIES OR MISSING COMPONENTS IMMEDIATELY

# Limited Warranty

**WARRANTY PROVISIONS :** Dickinson warrants this product to be free of defects in workmanship and materials for a period of one year. This warranty is limited to claims submitted in writing within a one-year period following the date of purchase. If any part of your new product fails because of a manufacturing defect within the warranty period Dickinson offers to replace said parts free of charge, provided, however, that such parts have not been improperly repaired, altered or tampered with or subjected to misuse, abuse or exposed to corrosive conditions. This warranty, however, is limited by certain exclusions, time limits and exceptions as listed below. Read these limitations and exclusions carefully.

**TIME LIMIT :** This warranty is given too and covers only the original purchaser. Coverage terminates one year from the date of purchase for parts replacement. **EXCLUSIONS :** This warranty does not cover or include : (a) Any normal deterioration of the product and appearance of items, due to wear and/or exposure; (b) any guarantees, promises, representations, warranties or service agreements given or made by an authorized distributor or other person selling this product, other than those specifically stated herein; (c) any damage or defect due to accident, improper repair, alteration, unreasonable use including failure to provide reasonable and necessary maintenance, misuse or abuse of the equipment, or exposure to corrosive conditions. This warranty is conditioned upon normal use, reasonable and necessary maintenance and service of your product, and written notice being given promptly upon Buyer's discovery of a warranty claim, pursuant to paragraph 6 below. Reasonable and necessary maintenance is maintenance which you are expected to do yourself or have done for you. It is maintenance, which is necessary to keep your product performing its intended function and operating at a reasonable level of performance.

**DAMAGE LIMITATION WARNING :** IN NO EVENT SHALL Dickinson BE LIABLE FOR ANY INCIDENTAL OR CONSEQUENTIAL DAMAGES, INCLUDING (BUT NOT LIMITED TO) LOSS OF USE OF THE PRODUCT, LOSS OF TIME, INCONVENIENCE, EXPENSES FOR TRAVEL, LODGING TRANSPORTATION CHARGES, LOSS BY DAMAGE TO PERSONAL PROPERTY OR LOSS OF INCOME, PROFITS OR REVENUE.

**ORAL OR IMPLIED WARRANTY LIMITATIONS :** The foregoing warranty is exclusive and in lieu of all other warranties, written or oral, expressed or implied, including but not limited to any warranty or merchantability or fitness for a particular purpose.

**TRANSFER LIMITATIONS :** This warranty is not assignable or transferable. It covers only the original purchaser.

**CLAIM PROCEDURE :** In the event of a defect, problem or that a breach of this warranty is discovered, in order to protect any warranty rights you must promptly notify Dickinson. Give name, address, and model name, location of unit, description of problem and where you can be reached during business hours.

**RESERVED RIGHT TO CHANGE :** Dickinson reserves the right to make changes or improvements to products it produces in the future without imposing on itself any obligations to install the same improvements in the products it has previously manufactured.

**SECOND OR SUBSEQUENT OWNER :** Dickinson does not give any warranty to secondary or subsequent purchasers, and it disclaims all implied warranties to such owners.

**INSPECTION :** To assist you in avoiding problems with your product and to validate this warranty you are required to do the following : (a) read the warranty; (b) inspect the product. Do not accept delivery until you have examined the product with your supplier; (c) ask questions about anything you do not understand concerning the product.

**OWNER REGISTRATION :** Fill out the WARRANTY CARD within 30 days from the date of delivery.

**WARRANTY :** RETURN OF THE CARD IS CONDITION PRECEDENT TO WARRANTY COVERAGE AND PERFORMANCE. IF YOU DO NOT FILL OUT AND MAIL THE CARD AS DIRECTED, YOU WILL NOT HAVE A WARRANTY.

**LEGAL RIGHTS :** This warranty gives you specific legal rights and you may also have other rights, which may vary within different government jurisdictions.

Return to:



SINCE 1932

**WARRANTY FORM**

I have read and understand the Limited Warranty and the Instruction Manual  
and agree to the terms and condition

(please print)

Date.....

Purchaser's Name.....

Address.....

.....

Model Name..... **Radex**.....

Serial Number.....

Date Of Purchase.....

Signature.....

Name of Seller.....

Seller Location.....

Note: The warranty info can be sent in via e-mail:  
[info@dickinsonmarine.com](mailto:info@dickinsonmarine.com)

**Dickinson Marine**  
#101-17728 66<sup>th</sup> AVE  
SURREY, BC V3S7X1 Canada  
Tel: 604-574-8641  
Fax: 604-574-8659  
E-mail: [info@dickinsonmarine.com](mailto:info@dickinsonmarine.com)  
Website: [www.dickinsonmarine.com](http://www.dickinsonmarine.com)

**All rights reserved. No part of this manual may be reproduced without permission in writing from Dickinson Marine. Dickinson also reserves the right to modify or change without notice, any materials, applications, equipment, accessories, and/or prices. All measurements and weights are approximate.**